

On Load Characteristic of the New Design Permanent Magnets Reluctance Generator

Andi Pawawoi¹, Syafii²

¹Electrical Energy Conversion Laboratory, Department of Electrical Engineering, Andalas University, Padang, Indonesia

²Transmission and Distribution Power System Laboratory, Department of Electrical Engineering, Andalas University, Padang, Indonesia

Article Info

Article history:

Received Oct 6, 2017

Revised Nov 13, 2017

Accepted Nov 28, 2017

Keyword:

Energy

New design generator

Permanent magnet

Reluctance

ABSTRACT

These The new design of a permanent magnet reluctance generator claimed to be able to convert the energy of the permanent magnet is the source of the main field into electrical energy, so that the generator output power can reach 167% compared with the input power axis. In this paper will discuss the characteristics of the generator voltage when under load, pure resistance, inductive load and capacitive load. The results showed that when given a purely resistive load, the terminal voltage tends to be constant, but if given the inductive load, the voltage drop occurs significantly approaching zero voltage at full load current. It is very different when loaded capacitive load. When the generator under load is capacitive, the generator voltage at full load increased by 224.7% from no-load voltage.

*Copyright © 2017 Institute of Advanced Engineering and Science.
All rights reserved.*

Corresponding Author:

Andi Pawawoi,

Department of Electrical Engineering,

Andalas University,

Limau Manis, 25163, Padang, Indonesia.

Email: andi_wawo@ft.unand.ac.id

1. INTRODUCTION

Permanent magnets can be used as an energy source and can renewed so that it can be a source of renewable energy. To get the design of permanent magnet energy conversion machine into electrical energy needed research. A new design reluctance permanent magnet generator claimed to have 167% efficiency output to the input shaft. This generator is able to absorb the energy from two sources simultaneously, namely; 1) permanent magnets which also became a source of major field and 2) drive shaft. 98% of the input comes from a permanent magnet generator and the rest of the drive shaft [1].

An advanced research is needed to determine the characteristics of the generator voltage during no-load and when loaded, either a purely resistive load, the load is inductive or capacitive loads. It is important to remember that a generator must be able to provide a relatively constant voltage, should only be changed more or less 10% of its nominal voltage according to its capacity [2].

In this study, the new design reluctance permanent magnet generator will be tested to give pure resistive load (R), the load is inductive (RL), and the load is capacitive (RC). The third type of load tested separately, and load regulation is done by adjusting the resistance value of each load. Values of L and C, as well as rotation in each test set constant.

2. BASIC THEORY

2.1. No-load characteristics generator

In conventional generators, the no-load characteristic is the terminal voltage value curve as a function of field excitation current and the value of the terminal voltage as a function of rotor speed. However, the generator that uses permanent magnets, no-load characteristics can only be expressed by the value of the terminal voltage as a function of rotor speed [3].

2.2. On-load characteristics genetaror

On- load Characteristics generator shows the condition of the state of the generator terminal voltage at no load to full load conditions, as shown in Figure 1 [4], and is usually called voltage regulation be expressed by the equation (1) [5].

$$\eta = \frac{V_{NL} - V_{FL}}{V_{NL}} 100\% \quad (1)$$

where:

η : voltage regulation
 V_{NL} : no load voltage
 V_{FL} : Full load voltage

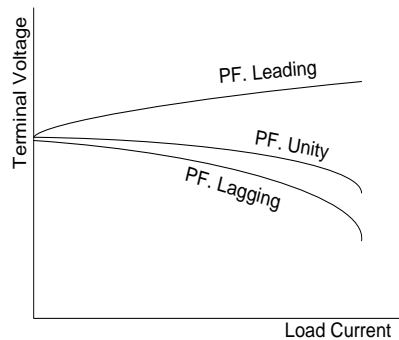

Figure 1. On-load characteristics generator

2.3. New desain generator reluktansi magnet permanen

2.3.1. Prototype

A permanent magnet generator reluctance new design has been made in previous studies, as shown in Figure 2. Details rotor dan stator prototype design shown in Figure 3 and 4 below [1].



Figure 2. Prototype of new design permanent magnets reluctance generator

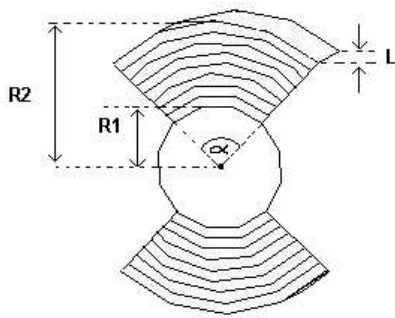

Figure 3. Specifications rotor
 $R_1 = 3 \text{ cm}$, $R_2 = 5.7 \text{ cm}$, $L = 2.4 \text{ cm}$, $\alpha = 90^\circ$

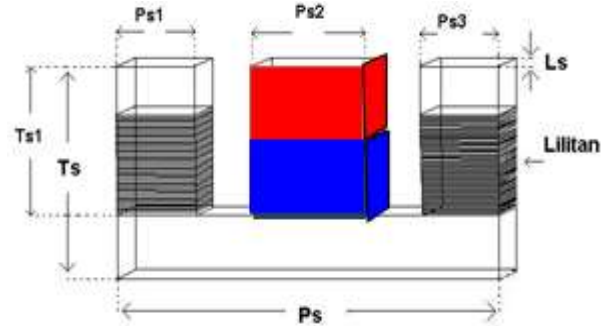

Figure 4. Specifications stator
 $P_s = 15.2 \text{ cm}$, $T_s = 10.1 \text{ cm}$, $L_s = 6.3 \text{ cm}$, $P_{s1} = P_{s3} = 2.5 \text{ cm}$,
 $P_{s2} = 5 \text{ cm}$, $T_{s1} = 7.6 \text{ cm}$, Number of winding = 530 turn,
 Size of copper = 0.5 mm

All permanent magnets used in this design are grade N35 neodymium magnets with length 22 mm, width 13 mm and thickness of 2.5mm, a total of 90 pieces arranged to form a 3x3 matrix as high as 15 pieces.

If the rotor is rotated and when it is exactly the stator gap, the flux from the permanent magnet will flow through the rotor and stator core re-enter. In line with the movement of the rotor in the gap stator, the magnetic flux passing through the core stator winding changes from a minimum value before the rotor into the gap stator until it reaches its maximum value when the gap stator closed by the rotor, and this value will return to the minimum value when the rotor out of the slit stator. This condition occurs alternately in the two core windings. Due to changes in the flux in the core where the armature windings are placed it will be generated voltage at the armature winding [6].

2.3.2. Power flow

In Figure 5, it is seen that the generator shaft power input is relatively constant at various load levels. This result is caused of using two rotors with intersecting rotors mounted. When the generator is operated, the electromagnetic torque of the two rotors will always opposite (destructively) at any time. The impact of the rotor design is the generator shaft power input will tend to constant despite increased load.

The comparison between power output and the power input of generator shaft, as shown in the input-output curve in Figure 5, there has been a condition where the generator output power greater than the power input shaft up to 167%.

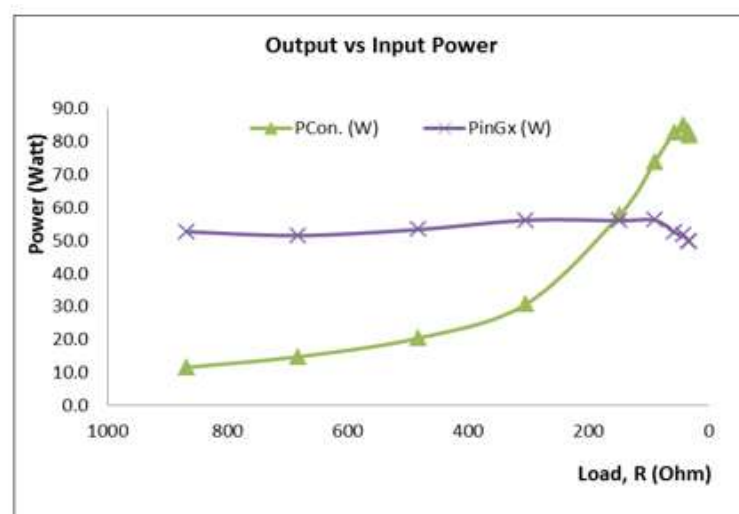

Figure 5. Graphic shaft input power and output power of the generator

With is applying the law of conservation of energy in the generator can be assured that the energy source of the generator is not entirely derived from the input shaft. If we note the reluctance generator working principle of this new design, the velocity of the rotor actually serve only divert the direction of magnetic flux flow from the permanent magnet to the right and left foot of stator core, alternately. Diversion of flux flow direction leads to changes in the magnetic flux in the core of both the stator armature windings so that induced voltage.

By considering on the process of transformer energy conversion, electrical energy initially converted into energy in the form of a magnetic field on the primary side, and then the magnetic field energy is converted back into electrical energy on the secondary side. Energy conversion system with a magnetic field media is possible only if the magnetic field changes with time. On the transformer, electrical source changes with time so that the magnetic field generated also changes with time. Magnetic field changes with time are passed to the secondary coil, and the secondary coil magnetic field energy is converted back into electrical energy [4].

On permanent magnet reluctance generator of this new design, a constant magnetic field of the permanent magnet is converted into magnetic field varies with time by the rotation of the rotor, the magnetic field by flowing to the right and left foot of stator core, alternately. Output coil is placed on the right and left leg stator feel the time-varying fields, so that in the coil, the magnetic field energy is converted into electrical energy.

When the permanent magnet reluctance generator new design is loaded, it will be generated magnetic field of the output coil. The magnetic field will oppose the magnetic field of the permanent magnet, so that if the continuous load plus the magnetic field in the core is reduced, consequently the converted energy will also be reduced, with its own generator output will drop. This is consistent with the experimental results as shown in the input-output curve in Figure 5. Scheme on the power flow when it reaches 167% conversion efficiency is shown in Figure 6. On the scheme shows that 83 W of power that is converted into electrical energy, 80.9 W (98%) comes from permanent magnet.

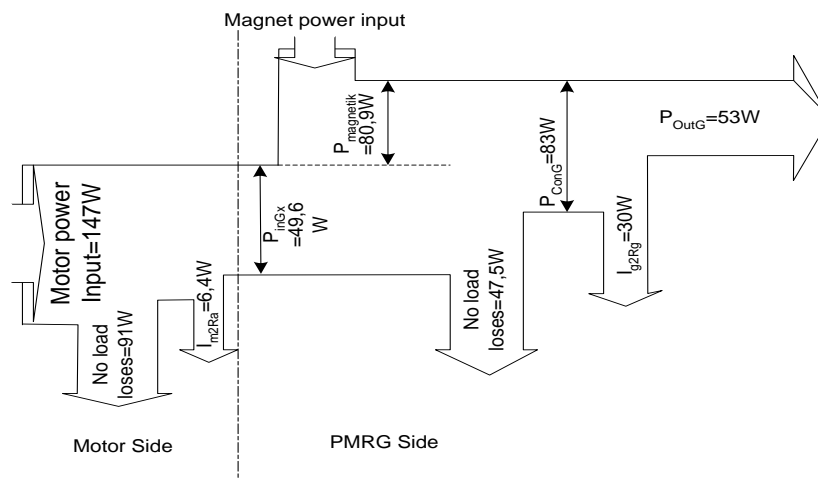

Figure 6. Power flow scheme

3. METODE

In testing this generator is used as a shunt DC motor driving, and all tests are carried out on the rotor speed of 2000 rpm. Desired data in this test is the voltage and load current. There are 4 types of tests performed, namely:

1. Testing RL load with variable R, where L is set constant 7 mH.
2. Testing RL load with L variables, where R is set constant 47 Ohm.
3. Testing RC load with variable R, where C is set constant 9 μ F.
4. Testing with C variable load RC, where R is set constant 47 Ohm

In RL load testing, first generator loaded with L constant 7 mH and R varied from the largest value (866 Ohm) to the smallest value (47 Ohm), then the value of R is kept constant 47 Ohm and L load values derived from 7 mH up to 0 H.

In the RC load testing, first generator loaded with constant C 9 μF and the value of R was varied from the largest value (866 Ohm) to the smallest value of R (47 Ohm), then the value of R is kept constant 47 Ohm and load value C derived from 9 μF up 0 μF . All data voltage test results are then converted into a voltage value to scale the same load current load by interpolation

4. RESULTS AND DISCUSSION

4.1. Results of testing

The test results of 4 types of tests performed are shown in Table 1 below, and the graph shown in the Figure 7. Primary data test results of all the tests have different scale current changes at every level of the load. To facilitate the analysis, the data were converted to the same scale with the current interpolation method.

Table 1. Current and Voltage on RC and RL Load

No	Load Current (A)	Voltage (V)			
		RC Load		RL Load	
		R Variabel, C = 9 μF	C variabel, R = 47 Ohm	L Variabel, R = 47 Ohm	R Variabel, L = 7 mH
1	0.0	105.0	105.0	105.0	105.0
2	0.1	113.1	107.8	95.2	80.9
3	0.2	129.2	117.1	91.6	77.9
4	0.3	147.6	126.6	84.3	71.7
5	0.4	168.6	147.3	71.6	60.9
6	0.5	200.3	180.3	46.7	39.7
7	0.6	249.0	220.1	29.9	25.4
8	0.7	287.0	251.4	20.1	17.1
9	0.8	309.9	287.2	15.3	13.0
10	0.9	341.2	328.2	12.2	12.0
11	1.0	341.0	341.0	9.2	9.2

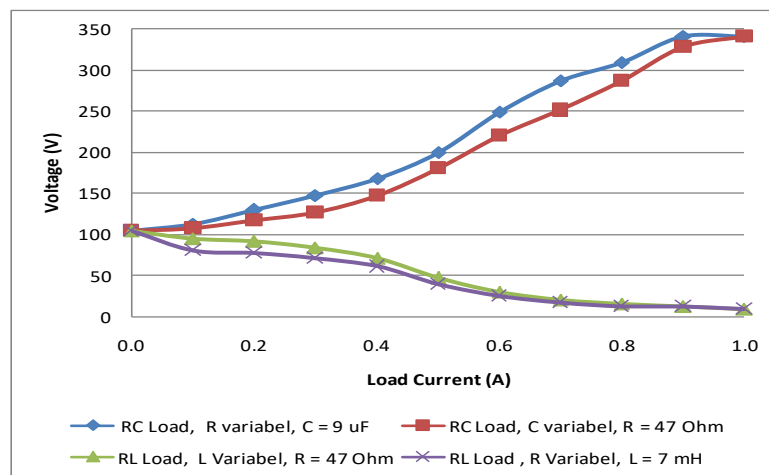

Figure 7. Characteristics on RC and RL load

4.2. Discussion

4.2.1. Characteristic on RC load.

When the generator is loaded with a capacitive load, the generator voltage will increase with increasing load current until the voltage reaches a saturation point at approximately 1 ampere load current. Increasing the generator voltage reaches 3.25 times compared with the no-load voltage, or if expressed as voltage regulation in accordance with equation (1) the regulation of -224.7%, minus sign indicates an increase in the voltage of 224.7% compared with the no-load voltage.

In the curves in Figure 7, voltage at the RC load with R variables as the state where the voltage is greater than the RC load with C variables at the same load current, this happens due to the load current value

of C larger composition (former power factor smaller) on the load R variables compared with the C variable load.

4.2.2. Characteristic on RL load.

In the inductive RL load voltage decline significantly, by 91.2% voltage regulation, both in load RL with R variables, as well as the RL load with L variables. At some point the load current seen the condition in which voltage at the RL load with variable R is lower than the voltage at the RL load with L variables, this happens because at that point the RL load with R variables have retarded the power factor lower. From all of these analyzes indicate that these generators must be equipped with voltage regulation system as the existing conventional generator.

5. CONCLUSION

Capacitive Load on these generators can cause voltage rises up to 224.7 percent of the no-load voltage. Inductive load on the generator can cause a voltage drop of up to 91.2% To be used properly, these generators must be equipped with voltage regulator system as a conventional generator voltage regulator system that already exists.

ACKNOWLEDGEMENTS

The author gratefully acknowledge the assistance rendered by the Faculty of Engineering, Andalas University for partially funding this publication in DIPA FT Unand 2015, (Contract No 005/UN.16.09.D/PL/2015)

REFERENCES

- [1] Andi Pawawoi, Syafii, "A New Design of Permanent Magnets Reluctance Generator," *World Academy of Science, Engineering and Technology International Journal of Electrical and Computer Engineering*, vol. 8, no. 2, pp. 461-468, 2014.
- [2] A.E, Fitzgerald., Ir. Djoko A. 1992. *Mesin-mesin Listrik, Edisi keempat*. Erlangga. Jakarta.
- [3] I, J, Nagrath. 1989. *Electric Machines*. Tata McGraw Hill. New Delhi.
- [4] BL. Theraja, *Text Book of Electrical Technology, Vol 2*, S. Chand, 2005.
- [5] Matsch.L, W. *Electromagnetic and Electromechanical Machines*. Third Ed. John Wiley & Son. Inc. 1987.
- [6] Pawawoi, A.. *Generator reluktansi model baru*, Polirekayasa, Padang, vol. 6, no. 1, 2010..

BIOGRAPHIES OF AUTHORS



Andi Pawawoi was born in Toamantan, Sinjai, Indonesia, in 17/10/1970. In 1998 is accepted as a Lecturer in the Department of Electrical Engineering Unand, he got the Master thesis Electrical Energy Conversion in 2002 from the Bandung Institute of Technology, Indonesia. His main scientific interests are free energy conversion and power electronic converter.



Syafii, Born in Lhokseumawe, Aceh in 1974. In 1998 is accepted as a Lecturer in the Department of Electrical Engineering Unand. He got the Master thesis Electrical power system in 2002 from the Bandung Institute of Technology; he has completed the doctoral program at Universiti Teknologi Malaysia in 2011. His main scientific interests are energy management and power sistem computation