

Security Constraint Unit Commitment Considering Line and Unit Contingencies-Particle Swarm Optimization

Mohammad Sadegh Javadi

Department of Electrical Engineering, Science and Research Branch, Islamic Azad University, Fars, Iran

Article Info

Article history:

Received Jan 29, 2012

Revised Mar 8, 2012

Accepted Mar 19, 2012

Keyword:

Contingency analysis

Incidence matrix

Independent system operator

Particle Swarm Optimization

Security constrained unit commitment

ABSTRACT

This paper presents a new approach for considering all possible contingencies in short-term power system operation. Based on this new approach, both generator and transmission line outages would be modelled in network-based power system analysis. Multi generator and also parallel transmission lines is modelled in this methodology. We also investigate this claim that feasibility and applicability of this approach is much more than the previous analytical methodologies. Security Constrained Unit commitment (SCUC) program which is carried out by Independent System Operator (ISO), is one of the complex problems which would be handled by this approach. In this paper, a DC-Optimal Power Flow (DCOPF) methodology has been implemented by particle swarm optimization technique. The Lagrangian Relaxation technique is based on the derivatives and the PSO is a non- derivative technique. These approaches are effective tools which can be implemented for short-term and long-term power system analysis, especially for economic analysis of restructured power systems. The DCOPF methodology has been considered for LMP calculation in LR, which is not available in PSO techniques. In the other hand, PSO technique may be able to provide the optimal solution, where LR usually getting stuck at a local optimum in a large scale power system. The simulation results show that the presented methods are both satisfactory and consistent with expectation.

*Copyright © 2012 Institute of Advanced Engineering and Science.
All rights reserved.*

Corresponding Author:

Mohammad Sadegh Javadi

Department of Electrical Engineering, Science and Research Branch, Islamic Azad University, Fars, Iran

e-mail: msjavadi@gmail.com

1. INTRODUCTION

The short-term planning of the market operation has been carried out in three stages. The first stage is three days-ahead load forecasting and receiving the first mature bids from generation companies. The second stage is extracting generation scheduling of accepted proposals and transferring the data to the all market participants. The third one is finalizing the market before 36 hours ahead for day-ahead energy market. After clearing the market before running the market all sharing of the production is announced and because of the pay as bid structure of the market, the participant's accepted price is determined.

In the short-term running the market a Security Constraint Unit Commitment (SCUC) problem should be executed to provides the market share and production schedule of all generating units. The day-ahead operation of market is depended on the execution of the SCUC problem. In large-scale power market, such as Iran's electricity market, the market operator must be equipped with the strong software to carries out this large scale optimization problem.

Enormous algorithms and formulation in this area are presented. Some of them are presented on modeling and formulation of the Unit Commitment problem [1], and some of them addressed the optimization techniques.

Solving methods of unit commitment can be divided into three species: classical ones, which are suboptimal algorithms based on priority list and equal incremental operating cost [2]; optimization ones, such

as Lagrangian Relaxation (LR) [3] dynamic programming [4]; intelligent searching ones, which use various intelligent techniques [5]. The first sort can solve the problem quickly, but only give suboptimal results, and from the point of view of optimization theory, they aren't precise. The second sort of algorithms is based on rigorous mathematical model, but there is dimension disaster in dynamic programming, and modeling conditions are very critical in such algorithms. In this paper, a linearizing approach is implemented to prevent dynamic programming disadvantages. The third sort of algorithm requires mathematically a less complex model but is more time consuming.

The recent developments in restructured electric power systems provide an opportunity for electricity market participants, such as GENCOs, TRANSCOs, and DISCOs, to exercise least-cost or profit-based operations. However, the system security is still the most important aspect of the power system operation, which cannot be overlooked in the Standard Market Design (SMD) [6].

In this environment, the GENCOs propose their bidding to maximizing their revenue and in the other side of the power market; DISCOs are trying to supply their demands by minimum cost and the ISO is supervising market clearing using the SCUC software and finally, the rate and winning amounts of each participant would be announced. Indeed, GENCOs and DISCOs compete in order to contribute in power market. Generation scheduling in a power system considers network security constraints and system's reliability indices. Hence, economic operation of the network is in the second preference.

ISO is the responsible entity of secure and economic operation of power system and has this authority to reschedule the UC program to maintain security. In security analysis, the ISO implemented SCUC software to ensure that the final generation scheduling has the ability to withstand sudden and potentially extreme disturbances such as short circuits or the loss of a major system component. Contingency Analysis (CA) is one of the main tasks which are incorporated by ISO to do this target. In CA, ISO performs the Security Constraint Optimal Power Flow (SCOPF) and considers both generator and transmission line outages. In network-oriented optimal power flow analysis the outages of transmission lines changes the structure of admittance matrix, which makes it considerably complex.

In this paper we propose the Incidence Matrix methodology to overcome the traditional challenges which are incorporated with admittance matrix based methodologies.

The remainder of this paper is organized as follows. Theoretical consideration of Security constraint Unit Commitment (SCUC) and corresponding mathematical formulation is addressed in next section. Modeling of the DCOPT based on incidence matrix is presented in section 3. Simulation case and results are introduced in section 4. Conclusion of this paper is conducted in last section.

2. SECURITY CONSTRAINED UNIT COMMITMENT

The unit commitment is one of the most important problems in power system operation. The objective function of vertically integrated utility system was minimizing the operation cost. This model is identified as a cost-based operation.

Actually, the output of the SCUC program has two parts, namely defining the units in operation, which are determined by "0" and "1" (integer variables) for on and off units respectively, and determining the quantity of the generation level of operating units considering the pollution criteria.

SCUC provides a financially viable unit commitment (UC) that is physically feasible. The generation dispatch based on SCUC is made available to corresponding market participants [7].

The unit commitment is a very significant optimization task, which plays a major role in the daily operation planning of power systems, especially in the framework of the deregulated power markets. The SCUC objective is to minimize the total operating cost of the generating units during the scheduling horizon, subject to a number of system and unit constraints [8].

The objective function of vertically integrated utility system was minimizing the operation cost. Therefore, this model is named cost-based operating system where the cost-based production, startup, and shutdown functions are considered in the SCUC formulation [9].

SCUC can provide an hourly commitment of generating units with minimum bid-based dispatch cost. The objective function (1) is composed of bid-based fuel costs for producing electric power and startup and shutdown costs of individual units for the given period. A typical set of constraints in SCUC includes:

- 1) power balance;
- 2) generating unit capacity;
- 3) system reserve requirements;
- 4) ramping up/down limits;
- 5) minimum up/down time limits;
- 6) maximum number of simultaneous on/off in a plant;
- 7) maximum number of on/off of a unit in a given period;

8) maximum energy of a unit in a given period

In monopolized and vertically integrated utility the objective was to meet the forecasted demand plus the spinning reserve to minimize the production cost, subject to each individual unit's operation constraints and system constraints.

In the competitive power market the objective for each generation company is now to maximize its profit. A company does not have the obligation to serve the entire load if it is not profitable [10]. On the other hand, in developed restructured power systems, the objective function is maximizing the social welfare. This model is the developed Bid-based one which the Hydro generation units and emission production limits are considered too.

2.1. SCUC Problem Formulation

In this part the SCUC problem is formulated. The first objective function in traditional approaches is shown in (1) which consists of three parameters: cost of generation, start up and shut down costs. The cost function was described by a quadratic or linear piecewise function. The hourly SCUC constraints listed below include the system power balance (2), system spinning and operating reserve requirements (3), (4), ramping up/down limits (5), (6), minimum up/down time limits (7), (8) and unit generation limits (9). Another constraint which is considered in this SCUC formulation is fuel constraints (10).

$$\begin{aligned} & \text{Min} \\ & \sum_{i=1}^{NG} \sum_{t=1}^{NT} [F_{ci}(PG_{it}) * I_{it} + SU_{it} + SD_{it}] \end{aligned} \quad (1)$$

For the sake of simplicity, linear cost function is considered where $F_{ci}(PG_{it}) = a_{Gi} + b_{Gi} PG_{it}$

$$\begin{aligned} & ST : \\ & \sum_{i=1}^{NG} PG_{it} = P_{D,t} + P_{L,t} \quad (t = 1, \dots, NT) \end{aligned} \quad (2)$$

$$\sum_{i=1}^{NG} R_{S,it} * I_{it} \geq R_{S,t} \quad (t = 1, \dots, NT) \quad (3)$$

$$\sum_{i=1}^{NG} R_{O,it} * I_{it} \geq R_{O,t} \quad (t = 1, \dots, NT) \quad (4)$$

$$\begin{aligned} & PG_{it} - PG_{i(t-1)} \leq [1 - I_{it}(1 - I_{i(t-1)})]UR_i + I_{it}(1 - I_{i(t-1)})PG_{i,\min} \\ & (i = 1, \dots, NG)(t = 1, \dots, NT) \end{aligned} \quad (5)$$

$$\begin{aligned} & PG_{i(t-1)} - PG_{it} \leq [1 - I_{i(t-1)}(1 - I_{it})]DR_i + I_{i(t-1)}(1 - I_{it})PG_{i,\min} \\ & (i = 1, \dots, NG)(t = 1, \dots, NT) \end{aligned} \quad (6)$$

$$\begin{aligned} & [x_{i(t-1)}^{on} - T_i^{on}] * [I_{i(t-1)} - I_{it}] \geq 0 \\ & (i = 1, \dots, NG)(t = 1, \dots, NT) \end{aligned} \quad (7)$$

$$\begin{aligned} & [x_{i(t-1)}^{off} - T_i^{off}] * [I_{it} - I_{i(t-1)}] \geq 0 \\ & (i = 1, \dots, NG)(t = 1, \dots, NT) \end{aligned} \quad (8)$$

$$\begin{aligned} & PG_{i,\min} \leq RG_{it} + PG_{it} \leq PG_{i,\max} \\ & t = 1, 2, \dots, T \end{aligned} \quad (9)$$

$$\sum_{t=1}^{NT} \sum_{i \in FT} [F_{fi}(PG_{it}) * I_{it} + SU_{f,it} + SD_{f,it}] \leq F_{FT}^{\max} \quad (10)$$

Where $F_{fi}(PG_{it})$ is a linear function same as the thermal generation cost function, $F_{ci}(PG_{it})$.

3. INCIDENCE MATRIX OPTIMAL POWER FLOW

As it mentioned above, SCUC problem formulation which is investigated in last decade is presented. Based on the constraints (2)-(10) it can be seen that these constraint imply that the SCUC problem is a Dynamic, Mixed Integer, Large Scale, Linear problem and it also should be augmented by considering line and generator outages. Henceforth, we present the Incidence Matrix formulation of OPF and address the flexibility of this methodology.

$$PG_{it} = \sum_{ug=1}^{NU} P_{i,ug,t} \quad (11)$$

$$PD_{it} = \sum_{ud=1}^{ND} D_{i,ud,t} \quad (12)$$

$$PG_{it} - PD_{it} = \sum_{j=1}^{NL} A(i,j) * PL_{jt} \quad \perp \quad \lambda_{it} \quad (13)$$

$$\sum_{i=1}^{NB} A(i,j) * \delta_{it} = \sum_{j=1}^{NL} X(j,j) * PL_{jt} \quad (14)$$

$$PL_j^{\min} \leq PL_{jt} \leq PL_j^{\max} \quad (15)$$

$$P_{i,ug}^{\min} \leq P_{i,ug,t} \leq P_{i,ug}^{\max} \quad (16)$$

For better illustration of modeling the multi units and multi consumer which may be located at each bus, aggregated generation and demand at each bus are represented in (11) and (12), respectively.

Generation and demand balance addressed in (13) by implementing the Incidence Matrix, this equation corresponds with injection power through power transmission lines connected to bus i at time t . Hourly locational marginal price, which is the dual variable of the balance constraint at bus i and indicated as λ_{it} . Hourly transmitted power through transmission lines is indicated as (14) using correspondence diagonal reactance matrix, X . Constraints (15) and (16) enforce the transmission capacity limits of each line and each generation unit, respectively.

The first step is extracting corresponding incidence matrix of the network. Figure 1 shows a simple network which consists of three buses and three lines. Each network can be represented as a graph and such a directional graph. Each bus indicated as a node and each transmission line addressed as a directed branch. In the corresponding incidence matrix, nodes and branches indicated as rows and columns, respectively. In the incidence matrix, "1" indicates if branch leaves node, "-1" if branch arrives at node and "0" if no connection.

It should be noted that the mathematical formulation in this paper extends the general formulation of single generator and single load for each bus. Aggregated production and load demand are modeled in this paper. Despite of recent papers which claim that actual implementation can be more complicated considering multiple generators and loads [11], the incidence matrix based formulation ignores both multiple generation units and multiple transmission lines between buses.

It also should be noticed that implementing the incidence matrix methodology eliminates the network interdependencies because of admittance matrix structure in conventional power flow. This approach would be useful in contingency analysis of power network. In contingency analysis it is very important to utilize a fix algorithm and eliminating the topological changes. For multiple generation units which installed in each bus, contingency analysis would be easily carried out, but for transmission line contingencies because of changing the admittance elements but in the incidence matrix formulation this objection has been removed.

One of the advantages of this network representation by using incidence matrix is appeared in contingency analysis which outages of both generation units and transmission lines would be modeled easily.

For example, when a transmission line outage is occurred, by assigning “0” in line capacity, the entire impacts of corresponding transmission line is eliminated easily [12].

In this section particle swarm optimization DCOPF is presented in which the hourly EDC is also included.

Particle Swarm Optimization (PSO) is an algorithm developed by [25] that simulates the social behaviors of bird flocking or fish schooling and the methods by which they find roosting places, food sources, and suitable habitat.

In the basic PSO technique, suppose that the search space is d-dimensional, such that:

- Each member is called a *particle*, and each particle (*i*-th particle) is represented by d-dimensional vector and described as $X_i = [x_{i1}, x_{i2}, \dots, x_{id}]$
- The set of n particles in the swarm are called *population* and described as $pop = [X_1, X_2, \dots, X_n]$
- The best previous position for each particle (the positions giving the best fitness value) is called *particle best* and described as $PB_i = [pb_{i1}, pb_{i2}, \dots, pb_{id}]$
- The best position among all of the particle best position achieved so far is called *global best* and described as $GB = [gb_1, gb_2, \dots, gb_d]$
- The rate of position change for each particle is called *the particle velocity* and it is described as $V_i = [v_{i1}, v_{i2}, \dots, v_{id}]$
- At iteration *k* the velocity for d-dimension of *i* particle is updated by:

$$v_{id}^{k+1} = wv_{id}^k + c_1r_1(pb_{id}^k - x_{id}^k) + c_2r_2(gb_d^k - x_{id}^k)$$

where $i=1,2,\dots,n$, and n is the size of population, w is the inertia weight, c_1 and c_2 are the acceleration constants, and r_1 and r_2 are two random values in range [0,1]. The optimal selection of previous parameters is found in [26-27]

- The *i*-particle position is updated by:

$$x_{id}^{k+1} = wv_{id}^k + c_1r_1(pb_{id}^k - x_{id}^k) + c_2r_2(gb_d^k - x_{id}^k) \quad (17)$$

The PSO technique can be expressed as follow:

Step 1. (*Initialization*): Set the iteration to number $k=0$. Generate randomly n particles, $\{X_i^0, i = 1, 2, \dots, n\}$, where $X_i^0 = [X_{i1}^0, X_{i2}^0, \dots, X_{id}^0]$, and their initial velocities $V_i^0 = [V_{i1}^0, V_{i2}^0, \dots, V_{id}^0]$. Evaluate the objective function for each particle $f(X_i^0)$. If the constraints are satisfied, then set the *particle best* $PB_i^0 = X_i^0$, and set the *particle best* which gives the best objective function among all of the particle bests to *global best*, GB^0 . Otherwise, repeat the initialization.

Step 2. *Update iteration counter* $k=k+1$

Step 3. *Update velocity* using Eq. (11)

Step 4. *Update particle best*:

$$\text{if } f_i(X_i^k) < f_i(PB_i^{k-1}) \text{ then } PB_i^k = X_i^k$$

$$\text{else } PB_i^k = PB_i^{k-1}$$

$$f(GB^k) = \min\{f_i(PB_i^k)\}$$

Step 5. *Update global best* : if $f(GB^k) < f(GB^{k-1})$ then $GB^k = GB^k$

$$\text{else } GB^k = GB^{k-1}$$

Step 6. *Stopping criterion*: If the number of iterations exceeds the maximum number iteration, then stop, otherwise go to step 2 [28].

In order to implement the PSO to the DCOPF problem, the variable matrix is included production level of generation units and bus angles, except slack bus in which the bus angle is set to zero. In the other words, $X_i = [x_{i1}, x_{i2}, \dots, x_{id}]$ is constructed by the PG_i and δ_i where $\delta_{\text{Slack}}=0$.

4. CASE STUDY AND SIMULATION RESULTS

In order to validate the proposed incidence matrix based SCUC validation, a RBTS six bus, nine lines test system, which is a standard test case, is considered here. The benchmark parameters are listed in

tables 1 and 2. Demanded load at buses 2, 5 and 6, are similar. The system is slightly modified from the RBTS 6-bus system [13] and will be used for the rest of this paper.

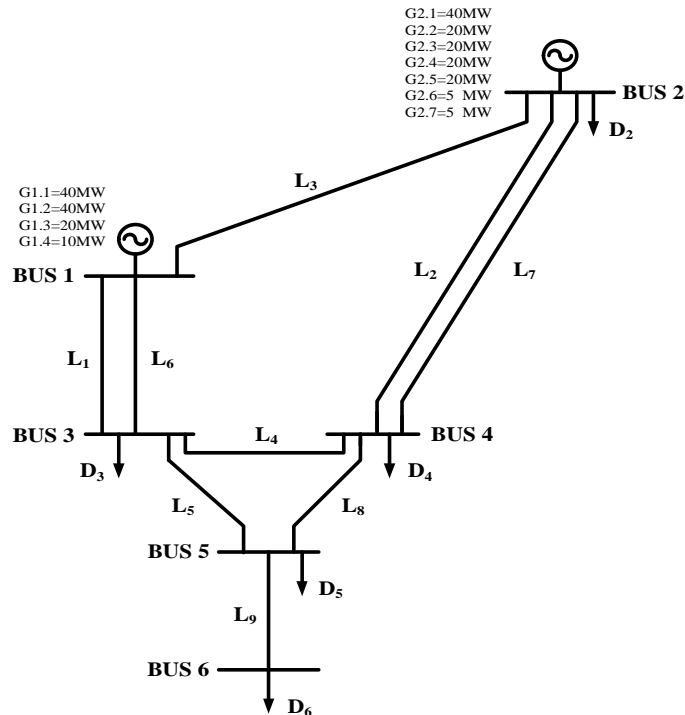

Figure 1. Single-line diagram of RBTS [14]

Table 1. Hourly Load Pattern of RBTS

Hours	P_D , MW				Hours	P_D , MW			
	$D_{2,5,6}$	D_3	D_4	Total		$D_{2,5,6}$	D_3	D_4	Total
1	13.40	56.95	26.80	123.95	13	19.00	80.75	38.00	175.75
2	12.60	53.55	25.20	116.55	14	19.00	80.75	38.00	175.75
3	12.00	51.00	24.00	111.00	15	18.60	79.05	37.20	172.05
4	11.80	50.15	23.60	109.15	16	18.80	79.90	37.60	173.90
5	11.80	50.15	23.60	109.15	17	19.80	84.15	39.60	183.15
6	12.00	51.00	24.00	111.00	18	20.00	85.00	40.00	185.00
7	14.80	62.90	29.60	136.90	19	20.00	85.00	40.00	185.00
8	17.20	73.10	34.40	159.10	20	19.20	81.60	38.40	177.60
9	19.00	80.75	32.25	170.00	21	18.20	77.35	36.40	168.35
10	19.20	81.60	30.80	170.00	22	16.60	70.55	33.20	153.55
11	19.20	81.60	30.80	170.00	23	14.60	62.05	29.20	135.05
12	19.00	80.75	32.25	170.00	24	12.60	53.55	25.20	116.55

Table 2. RBTS Generating Units Economical and Technical Data

Unit	P_{max}	P_{min}	a	b	T^{off}	T^{on}	UR	UD	SU	SD
1.1	40	4	540	17	4	4	40	40	40	40
1.2	40	4	540	17	4	4	40	40	40	40
1.3	20	2	473	1	3	3	20	20	20	20
1.4	10	1	185	20	2	2	10	10	10	10
2.1	40	4	540	17	4	4	40	40	40	40
2.2	20	2	473	1	2	2	20	20	20	20
2.3	20	2	473	1	2	2	20	20	20	20
2.4	20	2	473	1	2	2	20	20	20	20
2.5	20	2	473	1	2	2	20	20	20	20
2.6	5	0.5	131	18	1	1	5	5	5	5
2.7	5	0.5	131	18	1	1	5	5	5	5

The generation cost considered here as a linear function of generation level. This test system has 11 generating units which located at buses 1 and 2. Both thermal and hydro generation units are available in this case study. For better illustration parallel transmission lines and multi generating units are depicted in single line diagram. Transmission lines data and more detailed about this system can be seen in [14].

Based on previous considerations, the presented Incidence Matrix SCUC would be tested on generating units and transmission lines contingencies. For the sake of simplicity and brevity, we consider only base case test system and severe contingencies. In case 1, the base case results of SCUC are presented. Case 2 and 3 are about strict generation unit 1.3 and transmission line 3-4 (L4) contingencies, respectively. The statuses of generating units are presented in tables 3-5 for cases 1-3, respectively.

Table 3. Status of Generating Units for Case1, Base Case with no Contingencies.

Unit	1	2	3	4	5	6	7	8	9	10	11	12	13	14	15	16	17	18	19	20	21	22	23	24
1.1	1	1	1	1	0	0	0	0	0	0	0	0	0	0	0	0	0	0	0	0	0	0	0	0
1.2	0	0	0	0	0	0	0	1	1	1	1	1	1	1	1	1	1	1	1	1	1	1	0	0
1.3	1	1	1	1	1	1	1	1	1	1	1	1	1	1	1	1	1	1	1	1	1	1	1	0
1.4	0	0	0	0	1	1	0	0	0	0	0	0	0	0	0	0	0	0	0	0	0	0	0	0
2.1	0	0	0	0	0	0	1	1	1	1	1	1	1	1	1	1	1	1	1	1	1	1	1	1
2.2	1	1	1	1	1	1	1	1	1	1	1	1	1	1	1	1	1	1	1	1	1	1	1	1
2.3	0	0	0	0	1	1	1	1	1	1	1	1	1	1	1	1	1	1	1	1	1	1	1	1
2.4	1	1	1	1	1	1	1	1	1	1	1	1	1	1	1	1	1	1	1	1	1	1	1	1
2.5	1	1	1	1	1	1	1	1	1	1	1	1	1	1	1	1	1	1	1	1	1	1	1	1
2.6	0	0	0	0	0	1	0	0	0	0	0	0	0	0	0	0	0	0	0	0	0	0	0	0
2.7	1	0	0	0	0	0	0	0	0	0	0	0	0	0	0	0	1	1	1	0	0	0	0	0

Table 4. Status of Generating Units for Case2, Unit 1.3 Outage.

Unit	1	2	3	4	5	6	7	8	9	10	11	12	13	14	15	16	17	18	19	20	21	22	23	24
1.1	0	0	0	0	0	0	0	0	1	1	1	1	1	1	1	1	1	1	1	1	1	1	1	1
1.2	0	0	0	0	0	0	1	1	1	1	1	1	1	1	1	1	1	1	1	1	1	0	0	0
1.3	0	0	0	0	0	0	0	0	0	0	0	0	0	0	0	0	0	0	0	0	0	0	0	0
1.4	0	0	0	0	0	0	0	0	0	0	0	0	0	0	0	0	0	0	0	0	0	0	0	0
2.1	1	1	1	1	1	1	1	1	1	1	1	1	1	1	1	1	1	1	1	1	1	1	1	0
2.2	1	1	1	1	1	1	1	1	1	1	1	1	1	1	1	1	1	1	1	1	1	1	1	1
2.3	1	1	1	1	1	1	1	1	0	0	0	0	0	0	0	0	0	0	0	0	1	1	1	1
2.4	1	1	1	1	1	1	1	1	1	1	1	1	1	1	1	1	1	1	1	1	1	1	1	1
2.5	1	1	1	1	1	1	1	1	1	1	1	1	1	1	1	1	1	1	1	1	1	1	1	1
2.6	1	0	0	0	0	0	0	0	0	0	0	0	0	0	0	0	1	1	1	0	1	0	0	0
2.7	0	0	0	0	0	0	0	0	0	0	0	0	0	0	0	0	0	0	0	0	1	0	0	0

Table 5. Status of Generating Units for Case3, Transmission Line 3-4 (L4) Outage.

Unit	1	2	3	4	5	6	7	8	9	10	11	12	13	14	15	16	17	18	19	20	21	22	23	24
1.1	0	0	0	0	0	0	0	1	1	1	1	1	1	1	1	1	1	1	1	1	1	1	1	1
1.2	1	1	1	1	1	1	1	1	1	1	1	1	1	1	1	1	1	1	1	1	1	1	1	0
1.3	1	1	1	1	1	1	1	0	0	0	1	1	1	1	1	1	1	1	1	1	0	0	0	1
1.4	0	0	0	0	0	0	1	1	1	1	0	0	0	0	0	0	0	0	0	0	0	0	0	0
2.1	0	0	0	0	0	0	0	0	1	1	1	1	1	1	1	1	1	1	1	1	0	0	0	0
2.2	1	1	1	1	1	1	1	1	1	1	1	1	1	1	1	1	1	1	1	1	1	1	1	1
2.3	1	1	1	1	1	1	1	1	1	1	1	1	1	1	1	1	1	1	1	1	1	1	1	0
2.4	1	1	1	1	1	1	1	1	0	0	0	0	0	0	0	0	0	0	0	0	1	1	1	1
2.5	0	0	0	0	0	0	1	1	1	1	1	1	1	1	1	1	1	1	1	1	1	1	1	1
2.6	1	0	0	0	0	0	0	0	0	0	0	0	0	0	0	0	0	0	0	0	1	1	0	1
2.7	1	1	0	0	0	0	0	1	0	0	0	0	0	0	0	0	0	0	0	0	1	0	0	0

Simulation results show that in the case of contingencies the daily operation cost are much more than the base case. Daily operation cost of base case is 101560.95\$, however the operation cost of case 2 and 3 are 105166.85\$ and 107829.382\$, respectively.

5. CONCLUDING REMARKS

In this paper, the SCUC problem is introduced based on Incidence Matrix methodology. Network modeling via the proposed Incidence Matrix is a robust and reliable methodology for contingency analysis and economic consideration. In this method all possible outage in generating units and transmission lines

would be modeled by omitting or excluding the corresponding asset. The problem has been formulated as mixed integer dynamic linear optimization problem with competing fuel cost objectives.

In this paper we introduce the N-1 contingency for evaluating the robustness of proposed methodology. The proposed method does not impose any limitation on the number of contingencies and can be extended to include simultaneous (N-k) contingencies. Result of simulations shows that the proposed method is more efficient than the traditional ones, especially in evaluation of contingencies in power system. Simulation results verify the feasibility and capability of the proposed modeling of the short-term operation of power system.

REFERENCES

- [1] A. J. Wood and B. F. Wollenberg, *Power Generation, Operation and Control*. New York: John Wiley & Sons, 1996.
- [2] W. C. Merritt, C. H. Saylor, R. C. Burchett, and H. H. Happ, "Security constraints optimization—a case study," *IEEE Trans. Power Syst.*, vol. 3, no. 3, pp. 970-977, Aug. 1988.
- [3] S. Wang, M. Shahidehpour, D. Kirschen, S. Mokhtari, and G. Irisarri, "Short-term generation scheduling with transmission and environmental constraints using an augmented Lagrangian relaxation," *IEEE Trans. Power Syst.*, vol. 10, no. 3, pp. 1294–1301, Aug. 1995.
- [4] S. Wang and M. Shahidehpour, "Ramp-rate limits in unit commitment and economic dispatch incorporating rotor fatigue effect," *IEEE Trans. Power Syst.*, vol. 9, no. 3, pp. 1539-1545, Aug. 1994.
- [5] T. S. Dillon, K. W. Edwin, H. D. Kochs, and R. J. Taud, "Integer programming approach to the problem of optimal unit commitment with probabilistic reserve determination," *IEEE Trans. Power Appar. Syst.*, vol. PAS-97, pp. 2154-2166, Nov.-Sep. 1978.
- [6] M. Shahidehpour, H. Yamin, and Z. Li, *Market Operations in Electric Power Systems*. New York: John Wiley & Sons, 2002.
- [7] P. N. Biskas and A. G. Bakirtizis, "Decentralized security constrained DC-OPF of interconnected power systems," *IEE Proc. Gener. Transm. Distrib.*, vol. 151, no. 6, pp. 747-756, Nov. 2004.
- [8] M. S. Javadi, R. Azami, and M. Hassan, "Security Constrained Unit Commitment of Interconnected Power Systems," *International Review of Electrical Engineering I.R.E.E.*, vol. 4, no. 2, pp. 199-205, April 2009.
- [9] Y. Fu, M. Shahidehpour, and L. Zuyi, "Security-Constrained Unit Commitment With AC Constraints," *IEEE Trans. Power Syst.*, vol. 20, no. 2, pp. 1538-1550, May 2005.
- [10] G. B. Sheble, W. Charles, and J. Richter, "A Profit-Based Unit Commitment GA for the Competitive environment," presented at the IEEE/PES, 96WM New York, 2006.
- [11] F. Li and R. Bo, "DCOPF-Based LMP Simulation: Algorithm, Comparison With ACOPF, and Sensitivity," *IEEE Trans. Power Syst.*, vol. 22, no. 4, pp. 1475-1485, Nov. 2007.
- [12] M. S. Javadi, "Incidence Matrix-Based LMP Calculation: Algorithm and Applications " *International Journal of Multidisciplinary Sciences and Engineering, (IJMSE)*, vol. 2, no. 5, pp. 48-52, Aug. 2011.
- [13] PJM, "Training Materials-LMP 101, PJM.," 2005.
- [14] R. Billinton, S. Kumar, N. Chowdhury, K. Chu, K. Debnath, L. Goel, E. Khan, P. Kos, G. Nourbakhsh, and J. Oteng-Adjei, "A reliability test system for educational purposes- Basic Data," *IEEE Trans. Power Syst.*, vol. 4, no. 3, pp. 1238-1244, 1989.