

Interleaved Flyback Converter with Embedded Grid Interacting PV Cascaded MLI

Jaikrishna V, Subhransu Sekhar Dash, Linss T Alex, R. Sridhar

Department of Electrical and Electronics Engineering, SRM University, Chennai, Tamil Nadu, India

Article Info

Article history:

Received Jun 6, 2018

Revised Aug 12, 2018

Accepted Aug 27, 2018

Keywords:

Direct current

Maximum Power Point

Tracking

Multilevel inverter

Photovoltaic

Pulse Width Modulation

ABSTRACT

The importance of extracting power from renewable energy sources are increasing in the modern world as the power demand is increasing day by day and the non renewable energy sources are getting dried up. Solar power is a domestic source of energy and its availability throughout the year makes it a primary target to solve this crisis. It will never produce any hazardous waste or pollution. But various issues like Power quality problems and Harmonic distortion seep in due to the intermittent nature of PV system. This paper proposes a cascaded H-bridge multilevel inverter for grid connected PV system with a flyback converter. This helps to achieve maximum power point tracking and also provides isolation which will further help to increase system efficiency. The DC-DC flyback converters are cascaded to generate multilevel output voltage. Then this multilevel dc output is given to H bridge inverter to generate multilevel output. A new control algorithm is used in this paper which combines voltage-hold Perturb and observe method and modified PWM algorithm which helps to achieve the best MPPT. The proposed topology is implemented in PSIM. The Simulation and Hardware results reveal that the suggested technique is highly.

Copyright © 2018 Institute of Advanced Engineering and Science.
All rights reserved.

Corresponding Author:

Linss T Alex,

Department of Electrical and Electronics Engineering,

SRM University,

Kattankulathur, Chennai 603203, India.

Email: linsstalex@gmail.com

1. INTRODUCTION

Energy is one of the most important factors to survive in this modern world. As per Annual energy outlook 2017 the total demand of energy consumption increases by 11 % between 2016 and 2040. By that time the resources which we are using mostly for energy production such as oil and natural gas and nuclear will be taken out from the energy production business. The main reason for this is high price and fast depleting nature of crude oil and nuclear is hazardous and countries are not willing to open new plants [1]. This will lead us to energy less world. This brings into the picture the concept of utilizing energy sources like wind and solar. Among these the solar energy is always the first choice because of its availability all over the world. In this the obtainable irradiation from the sun is utilized with the help of PV modules which will result in pollution free energy which in turn is converted to useful energy with the help of inverters [2-4].

For synthesizing the ac output voltage without much distortion multilevel inverters will be the most suitable choice as it has got many advantages such as lesser harmonics, switching stress reduction and it also provides an option for generating high voltage. Neutral point clamped multilevel inverter, flying capacitor multilevel inverter and cascaded H-bridge multilevel inverter are some of the multilevel inverter topologies used. Due to the presence of diodes there will be an incremental loss and voltage imbalance in DC MLI [5]. In FC MLI the increased number of semiconductor and passive components results in increased complexity of the system [6]. Because of these drawbacks cascaded MLI was introduced for medium and high power

applications. Besides that the conventional power conversion topologies requires large number of power semiconductor switches and isolated dc sources. So a new area for research to reduce the number of components has emerged. This results in the development of new topologies.

For higher level generations the cascaded multilevel converter plays a crucial role due to its reduced component reduction. This will give an added advantage as it will also reduce the switching losses [7]. This paper develops a control technique of a PV system with multilevel inverter using a flyback transformer. It is almost similar to module integrated PV converter as it is made up of several modules connected in series. An H-bridge inverter is used at the output to convert the generated DC power to AC [8-10]. The flyback transformer will help to further reduce the number of power switches. Different control techniques like permutation of PV panels along with perturb and observe method increases the extraction from PV panel to the fullest [11-15]. But the main thing associated with any system that deals with PV is that at any radiation conditions the MPP tracking of all PV sources in the system should be achieved. The topology and control strategy adopted in this paper helps to achieve the MPP at all conditions. A control algorithm which combines a voltage-hold Perturbation & observation method with a modified PWM algorithm is used for achieving the maximum power generation for the converter levels. A simulation study and practical experimental test have been done on the setup and the results shows a significant improvement in PV system performance.

2. THE PROPOSED CONFIGURATION

The proposed configuration which is shown in Figure 1 consists of two power processing stages, DC-DC flyback converter and H-bridge inverter. The DC-DC converter is used to obtain individual MPPT and it also provides the necessary electrical isolation. Another advantage of this topology is that it uses only one converter per module which in turn helps to remove the misalliance between the panels

The suggested multilevel inverter architecture is made up of PV Modules; each PV module is connected to one DC-DC flyback converter. The output voltage of each flyback converter is cascaded to amplify the total input voltage to the inverter. The flyback converter provides the necessary isolation at high frequency and it also tracks maximum power of PV panel associated with it. Three PV panels are used in this topology to produce a seven level inverter.

From the Figure 1 PV1 is connected to one flyback DC-DC converter which consists of two winding transformer and similarly PV2 to second flyback DC-DC converter and PV3 to third flyback converter. The primary windings of the flyback transformer are connected to PV1 through a MOSFET SW1. The output of each flyback converter is cascaded and then connected to one H-bridge inverter. The inverter output is then connected to the grid. The main things that are to be considered in the proposed topology are

- a. Flyback transformer and its design
- b. Voltage-Hold Perturb & Observe Method
- c. Modified PV algorithm

2.1. Flyback transformer and its design

The flyback unit is used as an isolating transformer, DC-DC converter and also for tracking maximum power of PV panel associated with it. It has got two windings, primary and secondary. The output from the PV panel will be given to the primary of the flyback transformer through a switching device and the required output will be delivered from the secondary. The flyback transformer output depends on many factors such as core size, number of primary and secondary turns, air gap etc. The following section explains the effect of these factors on the output.

The flyback unit is used as an isolating transformer, DC-DC converter and also for tracking maximum power of PV panel associated with it. It has got two windings, primary and secondary. The output from the PV panel will be given to the primary of the flyback transformer through a switching device and the required output will be delivered from the secondary. The flyback transformer output depends on many factors such as core size, number of primary and secondary turns, air gap etc. The following section explains the effect of these factors on the output.

There are no simple equations linking transformer size and power rating. A large number of factors have to be considered such as properties of core material, shape of transformer, permitted temperature rise and the environment under which transformer will operate.

Size recommendations are usually for convection cooling and it's based on operating frequencies and temperature rise. Ferrite is usually selected for core material which is having high saturation flux density and low residual flux density. At operating frequency the losses in it will be low. The environment will not be free air and the temperature rise will be higher for restricted areas.

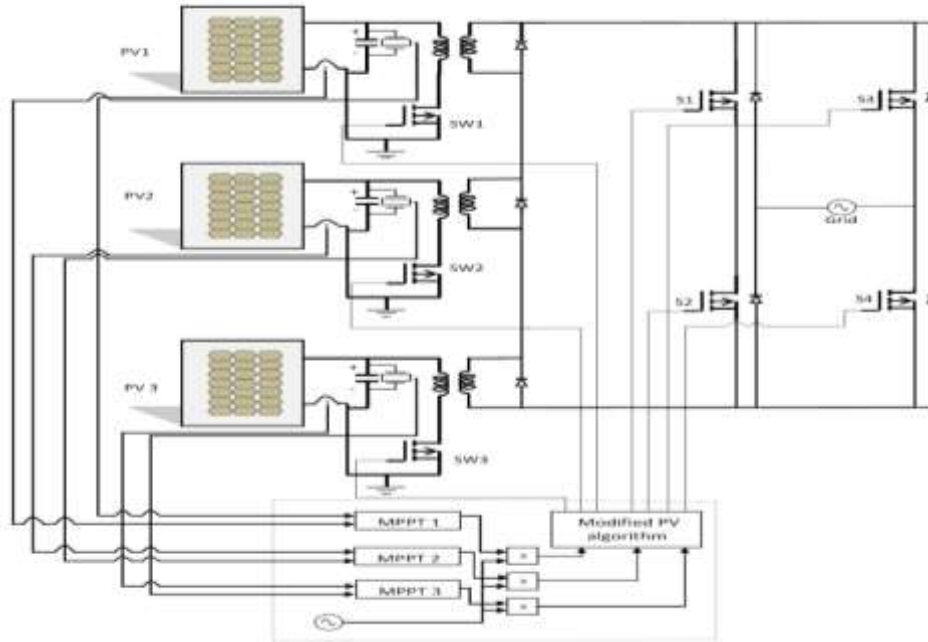

Figure 1. PV system with multilevel inverter

Volt-seconds approach is used to calculate the minimum number of primary turns for a single ON period as square wave is used as the applied voltage

$$Np_{min} = \frac{V_T}{B_m A_r} \tag{1}$$

where; Np_{min} =minimum primary turns
 V =applied dc voltage
 B_m =maximum flux density
 A_r =minimum cross sectional area of core, mm^2

The energy transfer from the primary to the secondary is also calculated by volt-seconds equation. If the flyback voltage referred to the primary is equal to the applied voltage, then the time taken to extract the energy will be equal to the time to input this energy.

$$Primary\ Volt/turn = \frac{V}{Np_{min}} \tag{2}$$

The number of secondary turns will be

$$N_s = \frac{V_s}{V/N} \tag{3}$$

where; N_s =secondary turns
 V_s =secondary voltage
 V/N =volts/turn

For the gapped core to have saturation, the magnetizing force (H) value should be much larger. This helps to withstand much larger DC current component. And also residual flux density is much lower giving a larger usable working range for core flux density. But as the permeability is lower, the inductance per turn will be smaller. Total length of air gap will be calculated using the equation

$$\phi = \frac{\mu_r (Np)^2 Ar}{L_p} \tag{4}$$

where; ϕ =Total length of air gap, mm
 $\mu_r = 4\pi \times 10^{-7}$
 Np =Primary turns
 Ar =Area of core, mm^2
 L_p =Primary inductance

$$L_p = \frac{V_X \Delta t}{\Delta i} \tag{5}$$

2.2. Voltage-hold perturb and observe method

Perturb and observe method is one of the finest methods for maximum power point tracking in PV system. The main problems associated with perturb and observe method is that it oscillates around an MPP for a longer time. During this time if the irradiation changes the MPP will also change. This sudden change won't be effectively tracked by the existing P & O method and will result in incorrect MPPs. So in this paper a modified version called Volt-hold P & O method is used.

The suggested method overcomes the limitations of existing P & O method. It uses a variable searching step size to stop oscillations for longer time around MPP. When there is no change in irradiation the tracking step size is slowly reduced to zero on reaching near to the MPP. But when changes happen, the tracking step size will restart and the value will automatically changes to initial value to maintain fast tracking. The change in irradiation can be detected by the number of changes within a fixed interval of time and by light level measurement. When the irradiation changes rapidly, the proposed method stops the searching method for the MPP. The VH P & O method might have different voltage values for different PV units as they track individually their reference voltage.

2.3. Modified PV algorithm

Another main thing in this system is the generation of PWM signals for PV units and inverter. To extract maximum power from the panel, the terminal voltage of PV should be almost equal to the individual reference voltage set by Voltage-hold P & O algorithm. As the PV units are connected as in a chain, the PWM reference signal for the whole system should be the sum of all individual reference voltages. The PV permutation algorithm switches alternate PV panels at single stage. But here in modified PV algorithm the PV panels will not be alternately turned ON at a time. The time period for which a panel should be turned ON will be totally depending on the irradiation.

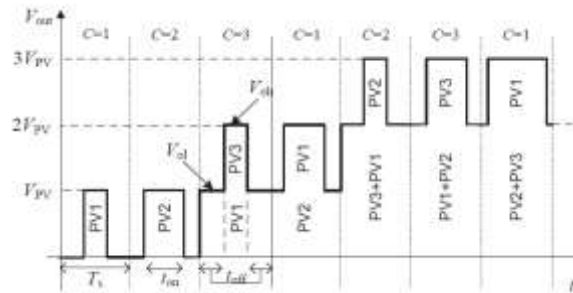

Figure 2. Modified PWM method through consecutive PWM switching cycles

At first, the direct PWM dictates the level of voltage at the output and also the time intervals. The reference voltage obtained from voltage hold process are normalized as

$$\bar{v}_{ref(f)} = \frac{|v_{ref(j)}(t)|}{V_L/n} \tag{6}$$

where VL equals voltage at maximum powerpoint for one panel at irradiance of 1000 W/m2 and the total number of PV sources is denoted by n

$$v_{offset(j)} = int[\bar{v}_{ref(j)}] \tag{7}$$

If $V_{offset(j)} > 1$, the corresponding PV source will be turned ON in that time interval by turning ON the switch and if $V_{offset(j)}=0$, the switch of corresponding source will be in off state thereby allowing the diode to bypass the source

$$t_{on(j)} = T_s \chi(\bar{v}_{ref(j)} - v_{offset(j)}) \tag{8}$$

3. RESULTS AND DISCUSSIONS

The simulation of multilevel inverter with interleaved flyback converter has been made in PSIM. The system consists of three PV modules which are then connected to a flyback converter. The flyback converters are cascaded in such a way that one flyback operates at a time and the diode helps to bypass the remaining levels thus producing a multilevel. The Table 1 shows the PV parameters used for the modeling. The modified PWM method is shown in Figure 3. In this method three separate signals are used for generating pulses for the working of the panels.

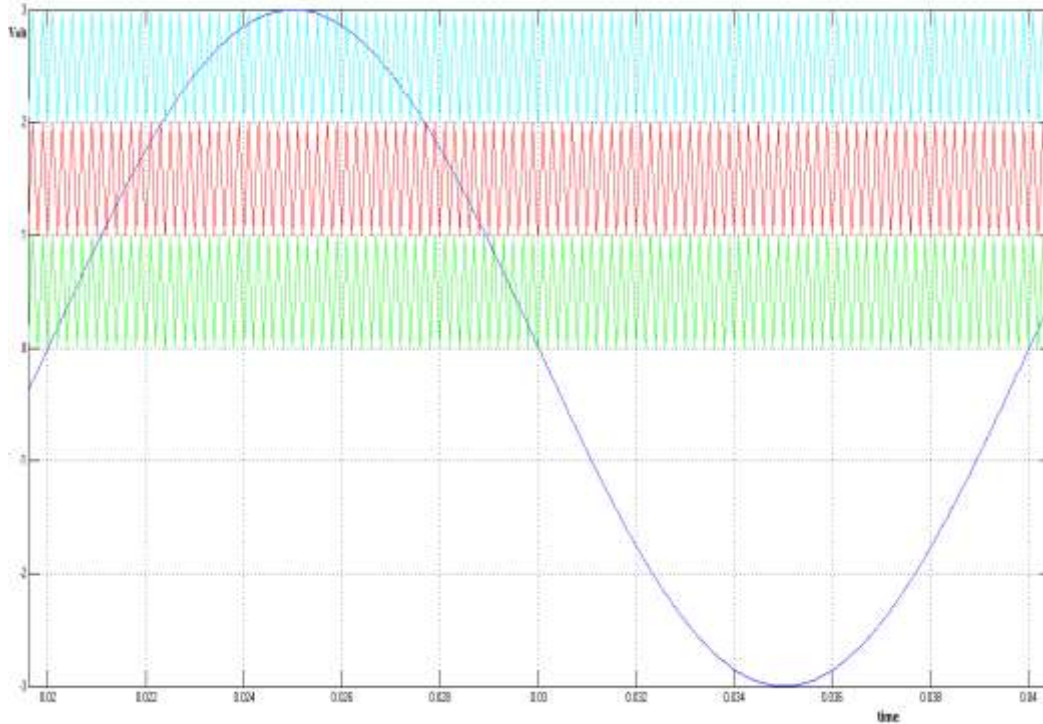

Figure 3. Modified PWM method in simulation

Table 1. PV Module Parameters Used in Simulation

PV Module Parameters	
Maximum power (Pmax)	10 W
Voltage at max power (Vmp)	16.032 V
Current at max power (Imp)	0.640 A
Open circuit voltage (Voc)	21.916 V
Short circuit current (Isc)	0.769 A
Power tolerance	± 3.0 %

The multilevel inverter output along with fundamental sine wave is shown in Figure 4. As three PV panels are used a seven level output will be obtained from the inverter. The first part of Figure represents a multilevel output which is the result of cascading the output of flyback converter and the output is also boosted using the flyback converter. The Figure 5 gives the current obtained at output of the flyback converter and the output current obtained. The Figure 6 shows the hardware implementation of the proposed method. It consists of three flyback transformers and output of each flyback is cascaded to generate a multilevel output. This output is then fed to H-Bridge inverter to create an ac waveform. As three flyback converters are used there will be a total of seven levels. In this proposed method the MPPT of each panel is calculated in panelwise as in a module integrated PV converter whereas the whole system uses only a single inverter like a central inverter system. The output voltage waveform obtained from the hardware is shown in Figure 7. The one division of Y axis is 40 V and x axis represents time in ms. The output obtained from the hardware matches with the result obtained from the simulation.

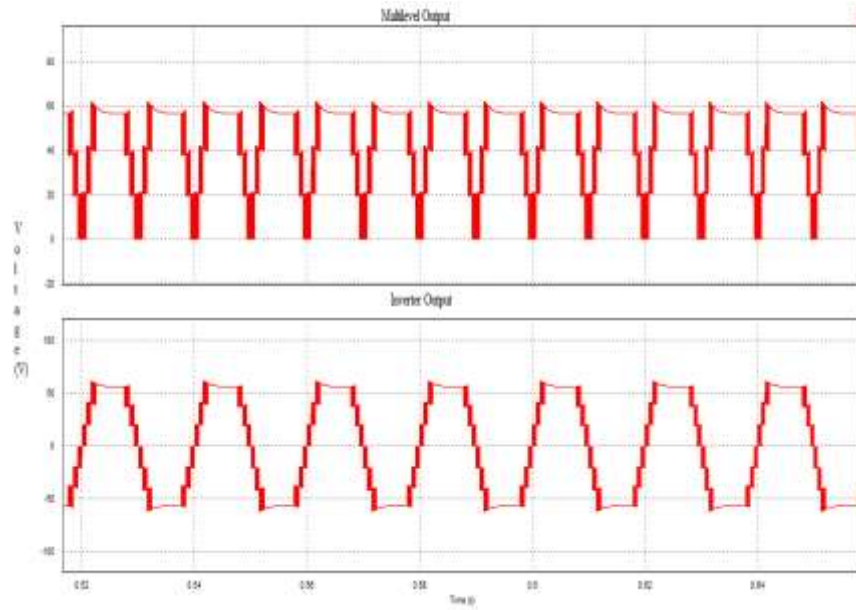

Figure 4. Graphs showing multilevel output and inverter output

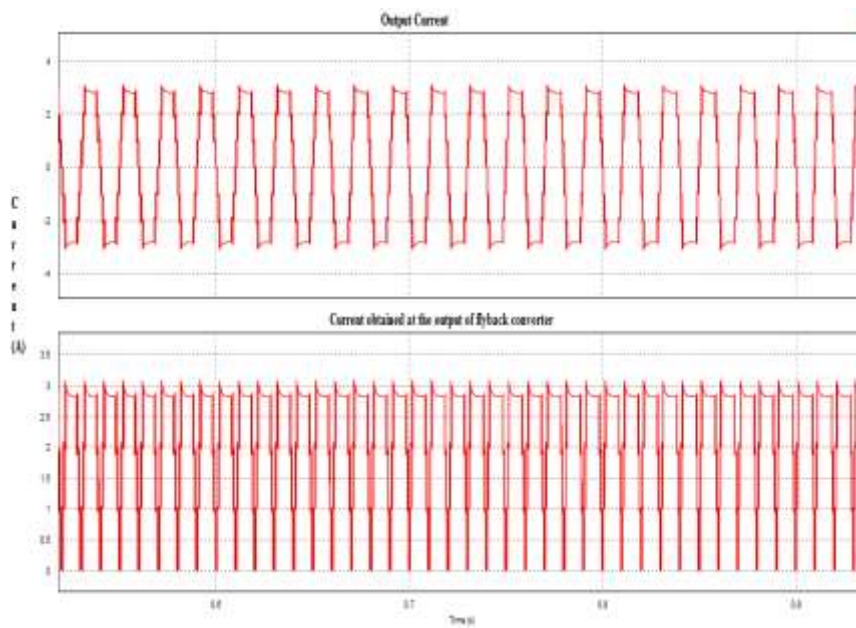

Figure 5. Graphs showing flyback output current and output current



Figure 6. Hardware model

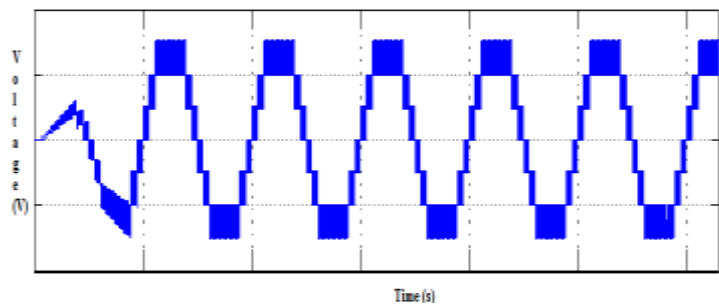

Figure 7. Output voltage waveform obtained from hardware

This configuration can have the advantages of both flyback converter and MLI which cannot give by an ordinary DC-DC converter. It provides Isolation when compared to method which is used in multilevel DC link converter. Voltage ratios are also multiplied due to the effect of Flyback. By reducing the power rating the efficiency of the Flyback is improved. Switching losses are also considerably reduced. This also analyses the drawbacks of perturb and observe algorithm and provide solutions to solve the issues. In this work a time constant is introduced so that the oscillations around the MPP stops at a particular time ensuring better tracking.

4. CONCLUSION

This paper proposed a grid interacting cascaded MLI with interleaved flyback converter for PV system. A flyback converter is provided for boosting the output from the PV panel and also to provide isolation. Diodes are used to bypass the converters thereby reducing the energy loss. This will helps in increasing the efficiency of the system. The control method used in this paper helps to track the MPP faster and accurately than the P & O algorithm. It keeps the configuration working in rapidly changing atmospheric conditions. The soundness of the suggested method is proved by simulation and hardware result.

REFERENCES

- [1] M. Apostolović and I. Škokljević, "Renewable energy sources development in south east European countries and its future prospects," *Mediterranean Conference on Power Generation, Transmission, Distribution and Energy Conversion (MedPower 2016)*, Belgrade, 2016, pp. 1-5.
- [2] B. M. T. Ho, S. H. Chung and S. Y. R. Hui, "An integrated inverter with maximum power tracking for grid-connected PV systems," *Nineteenth Annual IEEE Applied Power Electronics Conference and Exposition, 2004. APEC '04.*, Anaheim, CA, USA, 2004, pp. 1559-1565 Vol.3.
- [3] R. Sridhar and Subhransu Sekhar Dash et. al "Unified MPPT Controller for Partially Shaded Panels in a Photovoltaic Array" *International Journal of Automation and Computing*, vol. 11, no. 5, pp. 536-542, October 2014.
- [4] A. Sangwongwanich, Y. Yang and F. Blaabjerg, "High-Performance Constant Power Generation in Grid-Connected PV Systems," in *IEEE Transactions on Power Electronics*, vol. 31, no. 3, pp. 1822-1825, March 2016.
- [5] D. A. B. Zambra, C. Rech and J. R. Pinheiro, "Comparison of Neutral-Point-Clamped, Symmetrical, and Hybrid Asymmetrical Multilevel Inverters," in *IEEE Transactions on Industrial Electronics*, vol. 57, no. 7, pp. 2297-2306, July 2010.
- [6] J. Amini and M. Moallem, "A Fault-Diagnosis and Fault-Tolerant Control Scheme for Flying Capacitor Multilevel Inverters," in *IEEE Transactions on Industrial Electronics*, vol. 64, no. 3, pp. 1818-1826, March 2017.
- [7] Ali Ajami, Mohammad Reza Jannati, Ataollah Mokhberdorran and Mahdi Toupeh Khosroshahi, "Advanced Cascade Multilevel Converter with Reduction in Number of Components, " *Journal of Electrical Engineering & Technology*, vol 9, no. 1, pp. 127-135, 2014.
- [8] B. Xiao, L. Hang, J. Mei, C. Riley, L. M. Tolbert and B. Ozpineci, "Modular Cascaded H-Bridge Multilevel PV Inverter With Distributed MPPT for Grid-Connected Applications," in *IEEE Transactions on Industry Applications*, vol. 51, no. 2, pp. 1722-1731, March-April 2015.
- [9] I. Abdalla, J. Corda and L. Zhang, "Multilevel DC-Link Inverter and Control Algorithm to Overcome the PV Partial Shading," in *IEEE Transactions on Power Electronics*, vol. 28, no. 1, pp. 14-18, Jan. 2013. doi: 10.1109/TPEL.2012.2209460
- [10] A. M. Noman, K. E. Addoweesh and K. Al-Haddad, "Cascaded multilevel inverter topology with high frequency galvanic isolation for grid connected PV system," *IECON 2016 - 42nd Annual Conference of the IEEE Industrial Electronics Society*, Florence, 2016, pp. 3030-3037.
- [11] Sridhar, R. , Dhar, S. , Dash, S. S., "Performance analysis of a stand alone PV system with reduced switch cascaded multilevel inverter," *International Journal of Power and Energy Conversion*, vo. 6, no. 2, pp. 107-127, 2015.
- [12] I. Abdalla, J Corda and L. Zhang, "Optimal control of a multilevel DC-link converter photovoltaic system for maximum power generation," *Renewable Energy*, vol. 92, pp. 1-11, July 2016
- [13] A. Kalirasu, "A Novel Single Source Multiple Output Converter Integrating Buck-Boost and Fly Back Topology for SMPS Applications," *International Journal of Electrical Engineering and Computer Science*, vol. 8, no. 3, pp. 733-736, Dec 2017.
- [14] K. Deepa, Hridya Merin Saju and M. Vijaya Kumar, "Soft Switched Multi-Output Flyback Converter with Voltage Doubler," *International Journal of Power Electronics and Drive systems*, vol. 6, no. 2, pp. 396-403, June 2015.
- [15] Kah Haw Law, Wendy Pei Qin Ng and Wei Kitt Wong, "Flyback Cascaded Multilevel Inverter Based SHE- PWM Control for STATCOM Applications", *International Journal of Power Electronics and Drive systems*, vol. 8, no. 1, pp. 100-108, March 2017.