

A Step down Transformerless Single Switch Integrated Buck and Buck-Boost Converter

P.Maithili, C.Tharani, J.Nivedha, D.Soundarrajan

Electrical and Electronics Engineering Department, Kumaraguru College of Technology, India.

Article Info

Article history:

Received Sep 23, 2016

Revised Oct 20, 2016

Accepted Nov 8, 2016

Keyword:

Buck Buck-Boost converter,
MOSFET switch,
PI controller,
LC filter

ABSTRACT

This paper presents about the designing of the controller for integrated Buck Buck-Boost converter for maintaining the constant DC output voltage. This constant output voltage can be used for low voltage application. The absence of transformer includes the advantages of losses is less, efficient power factor and high efficiency. It provides the simple control structure with the positive constant output voltage .It operates on the closed loop with the designing of the PI controller for a MOSFET switch to provide the gate pulse. Whatever may be the input voltage it will produce the constant output voltage. The converter is successfully done by using MAT Lab/Simulink and verified the error reducing to negligible values.

Copyright © 2016 Institute of Advanced Engineering and Science.
All rights reserved.

Corresponding Author:

P.Maithili,
Electrical and Electronics Engineering Department,
Kumaraguru College of Technology,
India.
Email: maitheerainbow@gmail.com.

1. INTRODUCTION

The conversion of electric power from one form to another is done by converter. Various converters such as AC-DC converter (Controlled rectifiers), AC-AC converter (Voltage controllers), DC-AC converter (Inverter) and DC-DC converter (DC chopper) are used in power electronic circuits. With very few expectations, the distribution of power is in AC format .But the power supply in AC mains will introduce harmonic current in the utility side .This harmonics will cause severe problems to the system .Also the need for the DC power is mandatory for the industries This leads to the advancements of AC-DC converters .The major requirement for AC-AC converter is that it should have low input current distortion from electric power utility. Hence PFC is the major research part in Power Electronics Domain. In order to achieve high power factor, low THD and good output voltage regulation active PFC is employed rather than passive PFC. Active PFC is categorized into two stage approach and single stage approach. Because of high cost, low power density low conversion efficiency and complex control particularly in low power application the two stage approach is not implemented. To overcome the disadvantages single stage PFC topology is proposed.

SS converter topology has drawn much attention because of its cost effectiveness, compact in size and simple control mechanism. Most common SS converter topologies are buck, boost and buck-boost topologies, If the boost type topology is used in high line application ,the intermediate bus voltage is greater than input line voltage which can easily operate beyond 450V.But for low voltage application below 48V it will create stress on the components because of high intermediate bus voltage followed by a DC-DC converter for the output voltage regulation and also it cannot be able to limit the input inrush current and hence there should be provided with short circuit protection on the output. If buck-boost PFC is employed which leads to the negative polarity in the output terminal. With the simple step down DC-DC conversion (buck or buck-boost converter) which leads to the narrow duty cycle. This will cause many difficulties in circuit performance and efficiency.

Hence high step down transformer is employed. But usage of high step down transformer which leads to very high leakage inductance which causes high spike in the switch. For protection of the switch the snubber circuit should be included which increase the cost of the circuit. However most commonly used converter have complicated gate control because of usage of two switches. In the converter to increase the step down ratio based on the buck converter to eliminate the usage of intermediate capacitor is employed by using resonant technique.

In this paper, buck converter is used as PFC cell and Buck-Boost converter is used as DC-DC cell. This proposed integrated buck buck –boost converter is able to produce less intermediate bus voltage .Hence by designing the PI controller the voltage can be kept at constant value for the various input values.

This converter is able to achieve:

- In the absence of the transformer it has Low intermediate bus voltage and constant output voltage.
- Implementation of single switch which reduces the complexity of gate control in the circuit.
- The converter will produce the positive output voltage.
- The power is processed only once which leads to the high conversion efficiency.
- Inrush surge current protection is done by connecting the switch in series connection with the source.

The switching control technique of the proposed buck-boost ac-dc converter is simplified for the switches to drive. The output voltage of the converter is also regulated by PI controller. As a result, the proposed converter is operated with high efficiency for the low voltage application.

2. PROPOSED CIRCUIT CONFIGURATION

The proposed circuit is shown in Fig.1 merges the buck converter and the buck boost converter where buck converter is used as PFC cell and buck-boost converter is used as DC-DC cell. The circuit consists of integrated buck buck-boost Converters, filter, MOSFET switch.

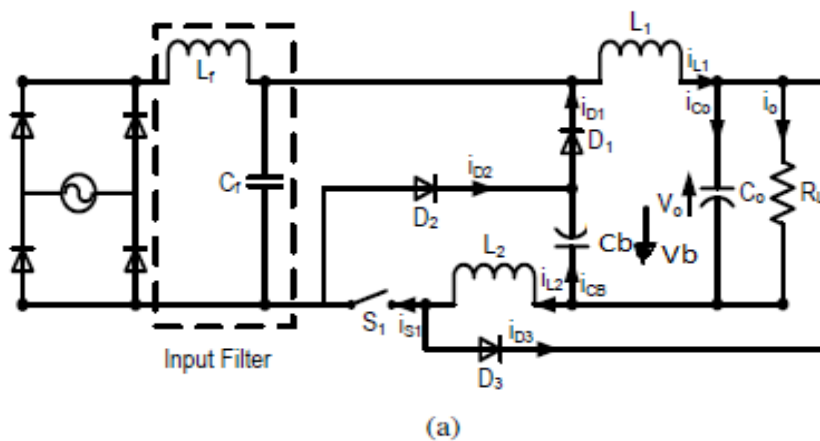

Figure 1. Proposed Integrated Buck Buck-Boost Converter

It is considered that signal to the gate in the switches is complicated one .In this proposed converter it has single MOSFET switch so complexity of the gate signal is reduced . Its consists of a series connected switch-diode pair with a resonant capacitor, which is operated to a loss-less snubber capacitor.

3. ANALYSIS OF CONVERTER OPERATION

To analyze the behavior of the proposed converter, the following assumptions are made:

- All components in the circuit is kept ideal.
- The input voltage $V_{in}(t) = V_{peak}(\sin \omega t)$ from which V_{peak} =peak voltage; ω =phase angle.
- The capacitors C_b and C_o are considered as constant DC sources without ripples because these capacitors are sufficiently large.
- The magnitude of the input voltage is kept constant within the switching period because $(f_s > f)$ where f_s =switching frequency; f =line frequency.

In the proposed converter (L_1, S_1, D_1, C_0, C_b) are considered as buck PFC cell and ($L_2, S_1, D_2, D_3, C_0, C_b$) are considered as buck-boost DC-DC cell. There is no current flows in the inductor L_1, L_2 at each switching cycle because .Both the cells are conducted in DCM(Discontinuous conduction mode).

The operation of the proposed converter over one switching cycle is divided into two modes of operation due to the characteristics of buck PFC cell.

A.Mode 1 [$V_{in}() < V_b + V_o$]:

In this buck PFC becomes inactive when the input voltage $V_{in}()$ is less than the sum of intermediate bus voltage and output voltage. So the buck PFC does not shape the line current.Hence, only buck – boost DC/DC cell deliver the supply to the load. In the half line period, two dead angle zones are present so there is no input current is drawn .In this mode there are three stages available. . Fig 2a, 2b, 2c represents the circuit diagram. Fig 3a represents the corresponding waveform

Stage 1 (d_{1T_s}):In this stage when S_1 switch is turned ON, Inductor L_2 gets charging linearly by intermediate bus voltage V_b . D_2 diode is conducting. Capacitor C_0 delivers the power to load. Fig 2a represents the circuit diagram.

Stage 2 (d_{2T_s}): In this stage when S_1 switch is turned OFF, Diode D_2 is conducting. The charge stored in the inductor L_2 is released to capacitor C_0 and load. Fig 2b represents the circuit diagram.

Stage 3 (d_{3T_s}): In this stage i_{L_2} is totally discharged and only C_0 sustain the load current. . Fig 2f represents the circuit diagram.

B.Mode 2 [$V_{in}() > V_b + V_o$]:

In this mode the input voltage is greater than the sum of intermediate bus voltage and output voltage. There are four stages available in this mode. . Fig 2c, 2d, 2e and 2f represent the circuit diagram. Fig 3a represents the corresponding waveform.

Stage 1 (d_{1T_s}): In this stage switch S_2 is turned ON .Here the inductors L_1 and L_2 are charged by $(V_{in} () - V_b - V_o)$. D_2 diode is conducting. The capacitor C_b gets charged linearly. . Fig 2c represents the circuit diagram.

Stage 2 (d_{2T_s}): In this stage switch S_1 is turned OFF. Current stored in the inductor i_{L_2} is discharges linearly to C_b and C_0 capacitors through D_0 ,so input power is connected directly to the load .The current is released to load when L_2 released to C_0 .When L_2 gets fully discharged this stage ends. Fig 2d represents the circuit diagram.

Stage 3 (d_{3T_s}): In this stage the inductor L_1 continues to deliver the current to the load and C_0 until the current reaches to 0.

Figure 2e represents the circuit diagram.

Stage 4 (d_{4T_s}): In this stage C_0 delivers the power output to the load. Figure 2f represents the circuit diagram.

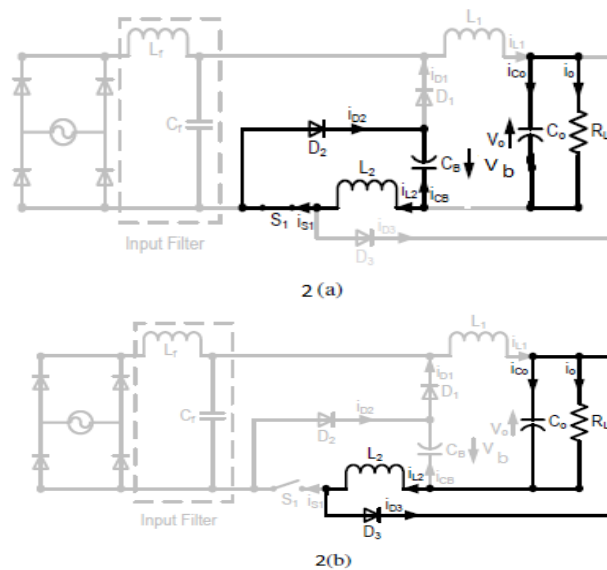

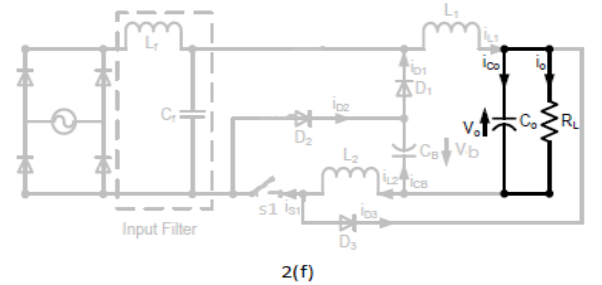
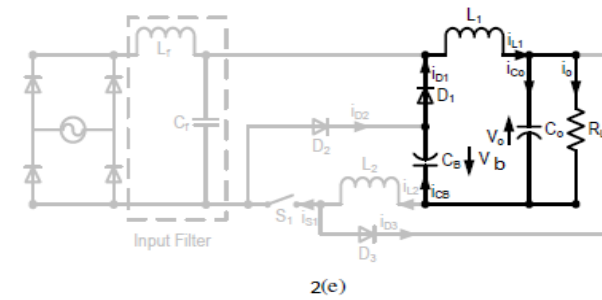
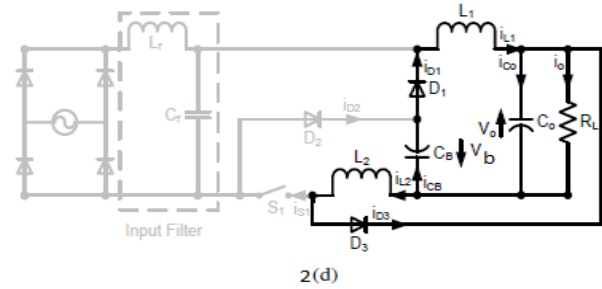
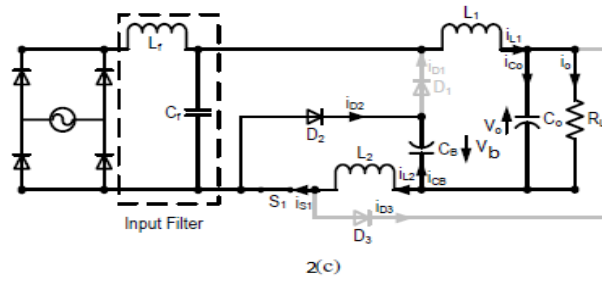

Figure 2. Circuit representation the corresponding proposed buck buck-boost converter.

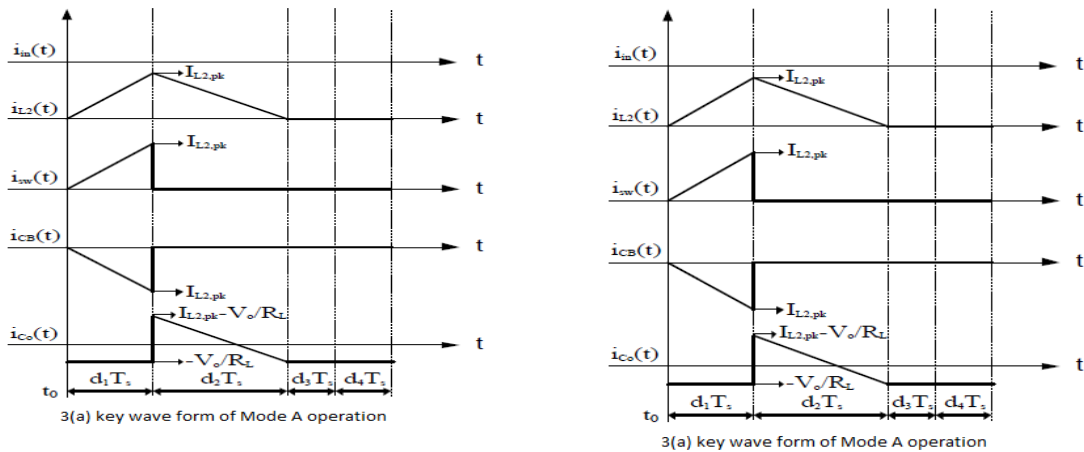
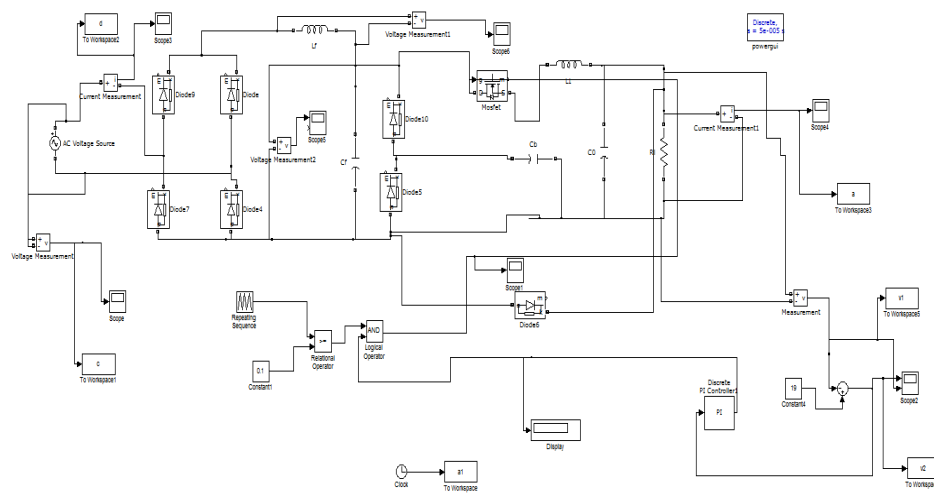

Figure 3. Key wave form of Mode A operation

5 SIMULATION RESULTS AND DISCUSSIONS

The new proposed Buck Buck-Boost converter is simulated by the following specification based on the design consideration .The simulated circuit has the input voltage which is varied from 90 V_{rms} to 200 V_{rms}.



A. Input and output voltage:

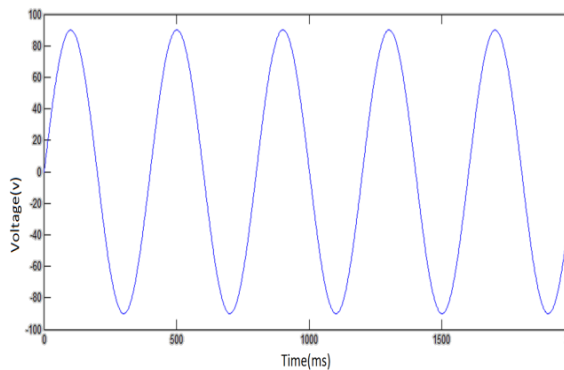

Figure 4 (a). Infers the input ac source voltage of 90 V.

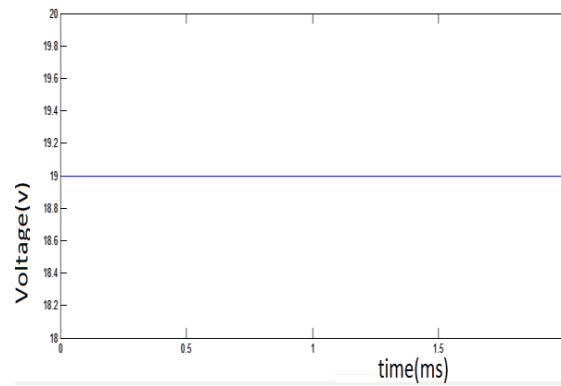

Figure 4 (b). Infers the constant dc output voltage of 19V.

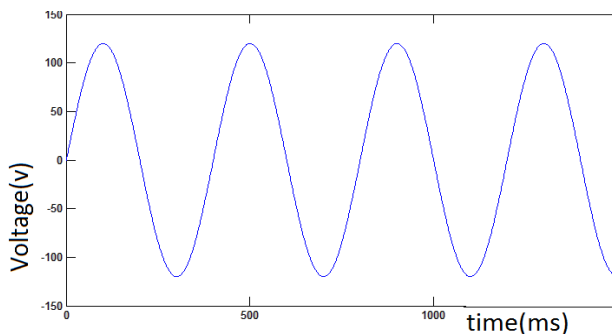

Figure 4 (c). infers the ac source input voltage of 120V.

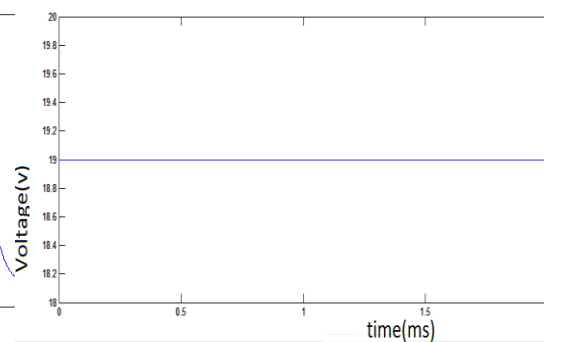

Figure 4(d). Infers the constant dc output voltage of 19V.

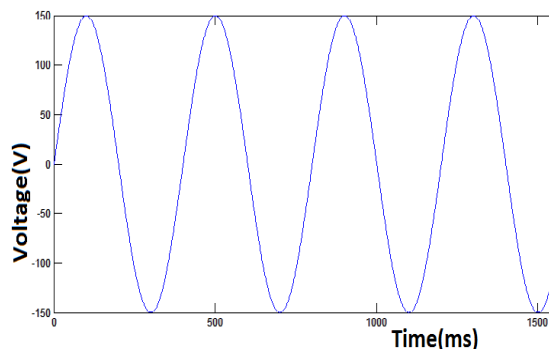

Figure 4 (e). infers the ac source input voltage of 150V

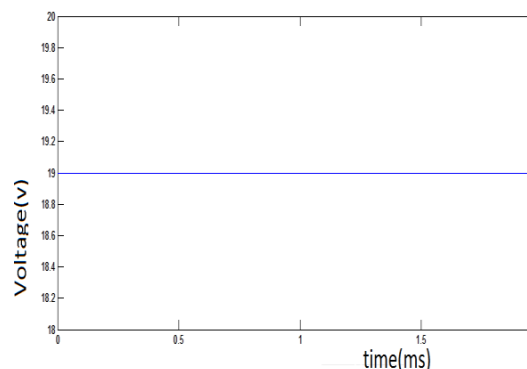

Figure 4 (f). Infers the constant dc output Voltage of 19V.

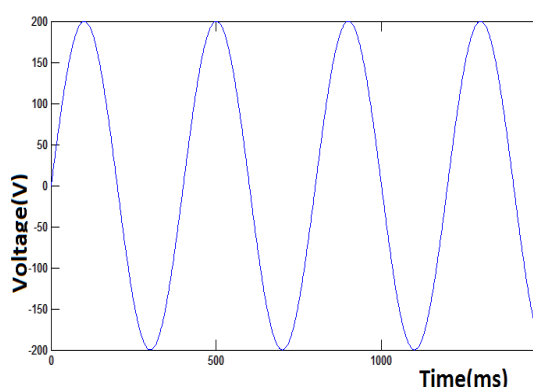

Figure 4(g). infers the ac input source voltage of 200V.

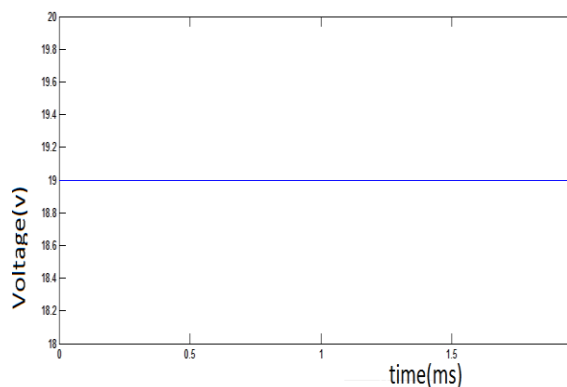

Figure 4 (h). infers the constant dc output voltage of 19V.

6 CONCLUSION

The proposed converter has been experimentally verified and results have shown good agreements with the predicted values. Owing to the absence of transformer, the demagnetizing circuit, the associated circuit dealing with leakage inductance, and the cost of the proposed circuit are reduced compared with isolated counter parts. This paper concludes that the voltage can be reduced efficiently for low voltage applications by using power electronics devices rather than using a transformer where the losses can be reduced. Efficiency can be increased by maintaining the constant output voltage without harmonics.

REFERENCES

- [1] Q.Zhao, F.C.Lee, and F.S Tsai "voltage and current stress reduction in single stage power factor correction AC/DC converters with bulk capacitor voltage feedback", *IEEE trans power electron*, vol 17, no.4, pp 477-484, jul 2002.
- [2] R.Redl and L.Balogh, "design considerations for single stage isolated power factor corrected power supplies with fast regulation of the output KI and LU : A HIGH STEP DOWN TRANSFORMERLESS SINGLE STAGE SINGLE SWITCH AC/DC CONVERTER 45 voltage" in *proc IEEE appl.power electron conf expo*, 1995 vol1, pp 454-458.
- [3] L.Antonio, B.Andrs, S.Marina, S.Vicente and O.Emilio, "New power factor correction AC-DC converter with reduced Storage capacitor voltage", *IEEE trans .Ind electron*, vol.54 no 1, pp 384-397, feb 2007.
- [4] E.H Ismail, A.J Sabzali and M.A. Al-saffar, "buck-boost type unity power factor rectifier with extended voltage conversion ratio", *IEEE Trans .Ind Electron*, Vol.55, no.3, PP-1123-1132, Mar 2008.
- [5] C.K Tse and M.H.L Chow, "Theoretical study of switching power converter with power factor correction and output regulation", *IEEE Trans circuits syst1, fundam theory Appl*, Vol 47, no 7PP 1047-1055 Jul 2000.
- [6] G.Hua, C.S Leu Y.Ziang and F.C Yee, "Novel Zero voltage transition PWM converters", *IEEE Trans Power Electron* Vol.9 no.2, PP 213-219, Mar 1994.
- [7] L.H.Dixon, High Power factor Pre-regulators for off-line power supply design sem, 1990, SEM 1990 PP 12.1-12.6.
- [8] S.K. Ki and D.D.C lu, "Implementation of an efficient transformer less single-stage single-switch ac/dc converter", *IEEE Trans. Ind Electron*, Vol.57, no.12, PP 4095-4105, Dec.2010.

-
- [10] J.M Alonso, M.A Dalla costa and C.ordiz “Integrated buck flyback converter as a high power factor off line power supply”, *IEEE Trans .Ind .Electron*, Vol.55, no.3, PP.1090-1100, Mar 2008.
- [11] J.H Park, H.G Kim, E.C Nho, T.W Chun and J.Choi, ‘ Grid-connected PV system using a quasi-z-source inverter,’ in proc. *IEEE ADEC*, Feb 15-19,2009, PP 925-929.